

milliMorph - Fluid-Driven Thin Film Shape-Change Materials for Interaction Design

Qiuyu Lu¹ Jifei Ou² João Wilbert² André Habén²
Haipeng Mi¹ Hiroshi Ishii²

¹Tsinghua University
Beijing, China
lqy17@mails.tsinghua.edu.cn
mhp@mail.tsinghua.edu.cn

²MIT Media Lab
Cambridge, USA
{jifei, jwilbert, ahaben, ishii}
@media.mit.edu

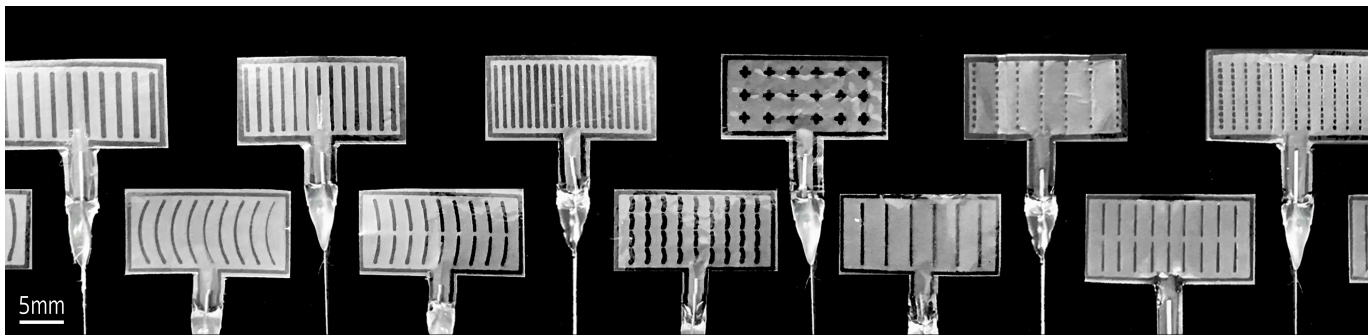

Figure 1. A collection of milliMorph films. When printing this page on A4 paper, this image reflects the actual physical size of the films.

ABSTRACT

This paper presents a design space, a fabrication system and applications of creating fluidic chambers and channels at millimeter scale for tangible actuated interfaces. The ability to design and fabricate millifluidic chambers allows one to create high frequency actuation, sequential control of flows and high resolution design on thin film materials. We propose a four dimensional design space of creating these fluidic chambers, a novel heat sealing system that enables easy and precise millifluidics fabrication, and application demonstrations of the fabricated materials for haptics, ambient devices and robotics. As shape-change materials are increasingly integrated in designing novel interfaces, milliMorph enriches the library of fluid-driven shape-change materials, and demonstrates new design opportunities that is unique at millimeter scale for product and interaction design.

Author Keywords

Shape-Changing Interfaces; Millifluidic; Microfluidic; Pneumatic; Fabrication

Permission to make digital or hard copies of all or part of this work for personal or classroom use is granted without fee provided that copies are not made or distributed for profit or commercial advantage and that copies bear this notice and the full citation on the first page. Copyrights for components of this work owned by others than ACM must be honored. Abstracting with credit is permitted. To copy otherwise, or republish, to post on servers or to redistribute to lists, requires prior specific permission and/or a fee. Request permissions from permissions@acm.org.

UIST '19, October 20-23, 2019, New Orleans, LA, USA

© 2019 Association for Computing Machinery.
ACM. ISBN 978-1-4503-6816-2/19/10...\$15.00

DOI: <http://dx.doi.org/10.1145/3332165.3347956>

CCS Concepts

•Human-centered computing → Interactive systems and tools;

INTRODUCTION

Fluidic-based (pneumatic & hydraulic) shape-change materials are of increasing interest in soft robotics and interaction design. Despite the challenges of tethered pumps and energy sources, fluidic-based shape-change materials provide lightweight and compliant design opportunities of future wearables, robots and interfaces. Recent advancements in fluidic-based shape-change materials explore the transformation topology[16, 38] interactivity[2, 31], source of fluid[12, 32] and change in properties beyond transformation[3, 17]. Among these works, the structural design and fabrication processes are essential to the promised functions, as they determine material properties and performance. In the field of wearable electronics, ultra-thin design and fabrication of electronics are gaining increasing attention of researchers[6]. Ultra thin film sensors (<5 μm) demonstrate the advantage of being lightweight, easy-to-attach and virtually imperceptible on human skin.

Inspired by the previously mentioned works, we will present fabrication methods and application prototypes of fluid-driven thin film actuators. While fluid-driven shape-change materials have been presented in HCI, little effort has been made to push the fabrication scale of chambers/channels below the centimeter-scale. Our experiment shows that by creating fluid chambers/channels at millimeter scale, we are able to achieve large folding transformations with small fluid quantities, high material actuation frequencies, and sequential control of actu-

Shape-Changing Primitives



Material Selections

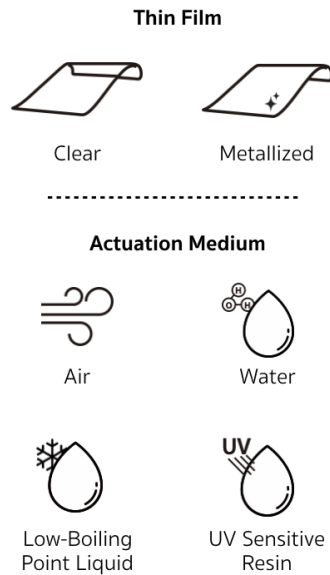

Embedded Sensing



Actuation Methods

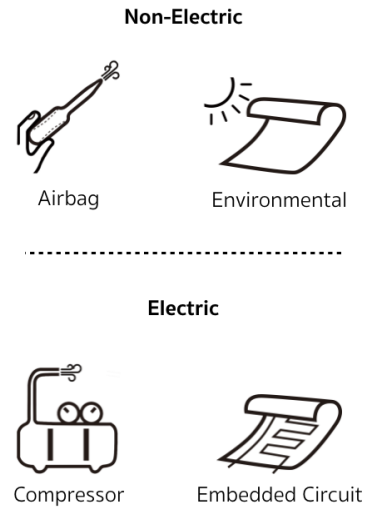

Figure 2. Four-dimensional design space for milliMorph.

ation. We believe these new features will expand the design space of the existing fluid-driven shape-change materials for HCI.

To do so, we introduce a novel CNC heat sealing platform that allows the precise fabrication of fluid chambers/channels, which we call Non-contact Hot Air Sealing (NoHAS). Inspired by aeroMorph[16], our system seals quasi non-elastic films like Mylar or PET without directly touching the surface of the film. With that, we were able to fabricate a chamber/channel as narrow as 0.5mm. This feature reduces the volume of fluid needed. We also leverage the metallic coating of commercially available film to create a sensing layer for interactivity. With the material characterization, fabrication process and application prototypes introduced in the paper, we show that fluid-driven shape-change material is scale-dependent. By scaling down the actuation unit, unique transformation becomes possible. We believe this work contributes to and expands on the library of thin film shape-change materials for HCI.

RELATED WORKS

Pneumatic / Hydraulic Driven Shape-Changing Interface

Pneumatically driven soft shape-changing materials have been intensively investigated in HCI. The PneuUI[38] project explored several shape-change primitives by compositing paper substrate with silicone rubber through a molding/casting technique. aeroMorph[16] introduced multiple heat-sealing methods to create textile-based pouches that fold into a variety of geometries. BlowFab[37] utilized thermal plastic to create reshappable pneumatic structures that can be used for furniture. Similarly, Printflatables[22] introduced a roll-to-roll system that can create furniture scale inflatable structures. Recently

Kenichi Nakahara et al.[12] proposed using a low boiling temperature liquid as a source of inflation to eliminate the need for a pneumatic pump. Nicholas Kellaris et al. [9] introduced the fast actuation of pouches filled with a liquid dielectric under very high voltage (6-10 kV). While the majority of projects investigate inflatable structures that are at centimeter or meter scales, we look at how to create arrays of chambers and channels at millimeter scale, in which we use both air and liquid to drive the actuation. We show that scale matters when it comes to the energy consumption, the quantity of fluid needed, the response speed and the control of shape-change sequences.

Micro- and Millifluidics System in Soft Robotics

The field of soft robotics has been a great inspiration for shape-change materials in HCI. Two of the most important aspects of these works are the fabrication of fluid chambers that enables actuation and channels that connect the actuation modules. Prior works have investigated methods like soft lithography[24, 32], precise laser machining[19, 21], 3D/4D printing[28] and direct heat-sealing[9, 10, 13] to create fluid chambers/channels. In our paper, we focus on how to create millimeter scale chamber/channels with off-the-shelf thin film materials and a CNC platform. This allows us to quickly iterate on the design without going through multiple steps like in molding/casting. The high precision of the platform also allows us to control the shape-changing sequences by carefully designing the channel.

Digital Microfabrication in HCI

Digital fabrication enables researchers in HCI to fabricate their own sensing and actuation materials for prototyping tangible interfaces. As the resolution of the fabrication machine

increases, one can also control the material properties. Several recent works[25, 30, 35] show how to use multimaterial 3D printing to create tunable optical effects or conducting light. Material stiffness can be also addressed by designing the multimaterial or microstructure[23, 40]. Cillia[15] and HapticPrint[27] also demonstrated how to control surface texture with high resolution 3D printing. BioLogic[39] presented a printing system creating thin film composite responsive material. All of these works show that as fabrication resolutions increase, we can create materials with extraordinary properties or transformations. Following this trajectory, our research shows that by fabricating fluid chambers at millimeter scale, we can create thin film shape-change materials with high responsiveness and controllable shape-change sequencing.

MILLIMETER SCALE FLUID-DRIVEN SHAPE CHANGE

The project milliMorph presents a shape-changing material based on the air pouch bending mechanism that [16] introduced. It is capable of performing deformations like bending, curling, twisting, and folding. Building on top of that, we show that milliMorph also opens up a new design space for creating compelling material shape-change. Overall, the new design space is enabled by pushing the fabrication limit of the current fluid-driven shape-change material to millimeter scale, which allows us to achieve very distinct shape-changing primitives, choose other mediums for actuation, adding ultra-thin sensing layer, etc. We classify the possibilities into four dimensions with the explanation of our design choices. The four dimensions are additionally illustrated in Figure 2.

Shape-Changing Primitives

High Resolution

With the precise NoHAS method, we are able to fabricate chambers and channels that respectively narrow to 1 mm and 0.5 mm scale. Thus actuation can be achieved at very high resolution. Compared with aeroMorph [16], which is usually at 2-5 cm scale, milliMorph makes it possible for smoother cantilever shape change instead of simple polygonal lines (Figure 3.a). Beyond cantilever-shaped structures, milliMorph can also be used to precisely pattern micro chambers in high density (Figure 3.b).

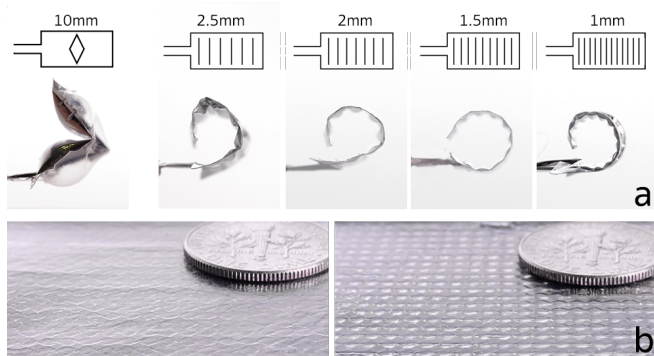

Figure 3. High resolution shape change: (a) Shape change is getting smoother as chambers becomes narrower. (b) Millimeter scale texture change, the size of each dots is ~1 mm × 1 mm.

High Frequency Actuation

Small amounts of fluid are needed to fully fill and actuate the thin film millimeter scale chambers. This characteristic enables the chambers to be inflated and deflated at a very fast rate compared to traditional larger scale fluid based systems. Being able to achieve high frequency actuation allows the creation of efficient robotic mechanisms and responsive shape changing interfaces. To evaluate the performance of milliMorph actuated under different frequencies, we fabricate a tested sample (10 mm × 20 mm, Figure 4.a) and design a platform to measure the bending curvature radius (Figure 4.b - f). By treating the chambers as a set of small cylinders approximately, the required volume, which is ~0.18 ml in this case, can be easily calculated with Equation 1, where d, l are respectively the distance between seams and the length of chambers. The curvature radius is then converted to curvature and the results are graphed in Figure 5. It shows the sample is quite responsive below 10Hz. When frequency becomes even higher, the sample will tend to vibrate quickly at small amplitude.

$$V = \sum_{n=1}^N \pi \left(\frac{d_n}{2}\right)^2 l_n \tag{1}$$

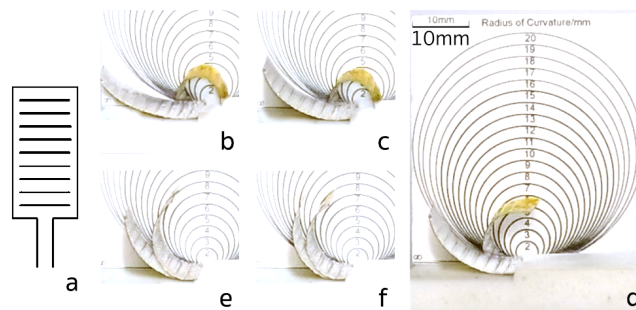

Figure 4. High frequency actuation: (a) Digital design of the tested sample. (b-f) The oscillation amplitude of tested sample when actuated at 1 Hz, 5 Hz, 10 Hz, 20 Hz, and 30 Hz. The air pressure is 2 bar and one side is covered with tape for better reversibility.

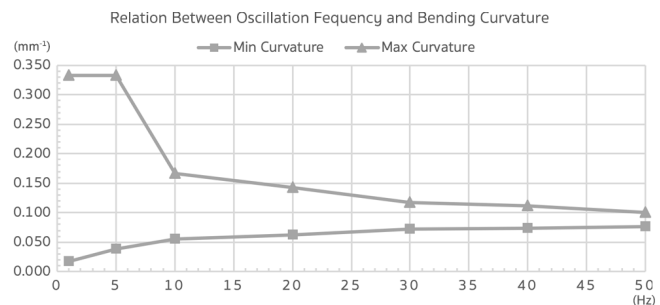

Figure 5. Relation between oscillation frequency and bending curvature

Sequential Control

At sub-millimeter scale, the diameter of each channel has a huge effect on how fluids will travel through the system and, consequently, the order in which different parts of the system

actuate. Flow resistance in circuit-like micro channels can be circulated with equation 2, where L , d , μ are respectively the length and diameter of channels, and dynamic viscosity. The resistance will dramatically increase when the diameter is decreased even slightly, hence greatly slowing down the flow rate. Equation 2 only applies to sub-millimeter scale. In centimeter or larger scales, one must change the diameter considerably and use high viscosity fluid to achieve significant flow rate change. The big channels require a large area to be placed and may act like pouches, causing unwanted deformation. Additionally, high viscosity and volume of the fluid requires very high power and a noisy pump to actuate. The ability to precisely design and fabricate millimeter scale channels allows one to design effective actuation systems based on predefined sequences or to react with specific logic to external stimuli (Figure 6). Compared to the prior work[1], milliMorph allows reversible sequential transformation.

$$R = \frac{128\mu L}{\pi d^4} \quad (2)$$

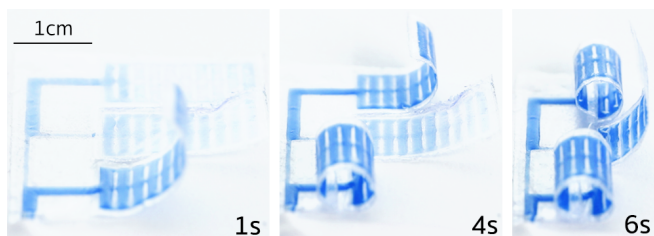

Figure 6. Sequential Control: Width of the smaller channels is $\sim 0.5\text{mm}$ and bigger channels is $\sim 1.5\text{mm}$

Material Selections

Thin Film

Researchers have developed ultra lightweight electronics thinner than $5\ \mu\text{m}$, making the intimate integration of electronic devices into everyday life possible [6]. NoHAS enables us to fabricate milliMorph with ultra thin film, pushing shape-changing interfaces further to be imperceptible when idle. Furthermore, compared with the sheet materials used in [16], the thin film materials are very lightweight and relatively soft, which is critical for ideal bending performance as the actuation force decreases when chambers become smaller. The industry can make heat-sealable film as thin as $6\ \mu\text{m}$ nowadays, however the cost is very high and it requires large orders to produce. As a trade-off between thickness and commercial availability, standard $20\ \mu\text{m}$ heat-sealable PET film is currently chosen. In milliMorph, both clear and metallized PET were explored. For usages where transparency is required, such as optical change, clear film can be adopted. Clear film is also very useful for evaluating the fabricated design. For example, laminating paper will turn from being translucent to being transparent when sealed, which makes it excellent to observe the seams. Metallized film can be used when an embedded circuit is needed as the metal layer coated on the film can be leveraged to fabricate the circuit traces.

Actuation Medium

As we can create fluid chambers and channels at millimeter scale, the actuation medium for milliMorph can be much more diverse. Here we showcase four possibilities: air, water, low boiling point liquid and UV sensitive resin.

1. When using air as the actuation medium, given its fast travel rate through micro channels, it enables the films to be actuated at very high frequency.
2. Compared with the pneumatic system, the hydraulic system usually requires more energy to power and has a slower system response. However, as milliMorph requires a very small volume of medium, it can be driven by hydraulic systems with low energy consumption. Water is suitable for sequence control and obtaining higher stiffness.
3. The phase change of low boiling point liquid has the advantage of being untethered, enabling milliMorph to be used in mobile and wearable contexts with no need of an external system. Given the phase changing rate of a low boiling point liquid, it usually takes longer to respond and reverse [12]. Since milliMorph needs less volume change to complete the same transformation and has bigger surface-area-to-volume ratio, it requires less energy and the heat exchange is more efficient. Thus the response and reverse time can be much shorter. Products such as 3M™ Novec™ Engineered Fluids offer various choices of liquids with boiling points beginning from 34°C at 1 atmosphere pressure, which can be used as a phase change actuation medium.
4. Photosensitive resin can be injected and cured for permanent 2D to 3D fabrication. It requires a significantly smaller volume of resin compared to traditional 3D printing.

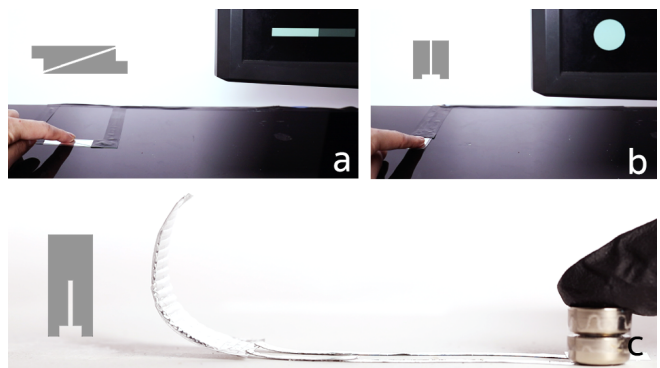

Figure 7. Embedded Circuit: (a) A slider. (b) A touch sensor. (c) A resistor is etched on a milliMorph sample and powered by two 1.5v button batteries to heat low boiling point liquid inside.

Embedded Sensing

Sensing ability is crucial for building responsive and interactive interfaces. However, given the characteristic of milliMorph being a thin film composite, there is a challenge in how to elegantly embed sensing circuitry without compromising the softness and lightness of the item. In order to fully embed the sensing system into the thin film we used metallized Mylar, the commercially available heat-sealable thin film commonly used as the main material for helium balloons. It's coated with aluminum thinned down to $20\ \text{nm}$ through an industrial physical vapor deposition process. For a $40\ \text{nm}$ thick

coat, the surface resistance is $\sim 1.5 \Omega/\text{sq}$. Leveraging the metal layer, we are able to directly etch different circuit designs on the milliMorph thin film. While similar method has been proposed to make electrodes for generating electrostatic forces[9], we further explored its potential of making sensing / heating circuit and how to improve the robustness (Figure 7). Aside from control by an external system, the low boiling point liquid medium allows milliMorph to respond to the temperature change utilizing the medium's phase transformation.

Actuation Methods

MilliMorph can be actuated non-electrically or electrically. One simple non-electric way is connecting a small airbag such as a pipette and squeezing manually. The low amount of air is sufficient to generate a desired shape change in most cases. In other circumstances where a greater volume, higher flow rate, or more precise control is required, a compressor, control board, and valves can be used. The other non-electric approach is injecting low boiling point liquid. This way milliMorph can react to the environmental temperature shift and change shape accordingly. In this case, milliMorph can also be driven by embedded heating circuits electrically (Figure 7.c).

FABRICATION PROCESS

The fabrication process of milliMorph composites can be divided into four steps. The designer creates a digital drawing of the composite structure, then fabricates this structure using a Non-contact Hot Air Sealing (NoHAS) platform and etches circuit (Figure 8,9,10), and finally connects the tube or injects a different liquid medium before closing the seal.

Digital Design

Common drawing software such as AutoCAD, Illustrator and CorelDRAW can be used to design the seam and circuit pattern. The width of the fluid chamber should be designed higher than 1 mm, so that the injected fluid can fully fill the space. For channels, the space should be no thinner than 0.5 mm, or the fluid might not be able to pass through. The thinner channels are also likely to get blocked when film crinkles. Since the design of the fluid chamber/channel is at millimeter scale, the actual width of the seams should be taken into account when doing digital design. As for the shape of the seams, there are many choices such as straight full / dashed line, dot, arc, and small diamond (Figure 1). Compared with the others, the line and diamond shape have the best bending performance. However, sealing a diamond seam would take 2-3 times longer than sealing a line seam. So, we recommend designing the patterns with a line shape. After the drawing is done, the designer can use open source software such as Inkscape and Universal G-Code Sender to generate G-Code and control the NoHAS platform.

Non-Contact Hot Air Sealing (NoHAS)

Common heat sealing tools involve direct contact between the heating element and the sealing materials. As the heating element moves against the materials, it will leave indentations and sometimes damage the surface. aeroMorph deals with this by using a ball bearing sealing tool (diameter: 6 mm)[16]. However, to achieve thin seams for milliMorph, the heating

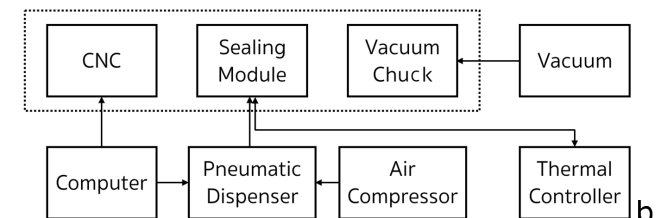
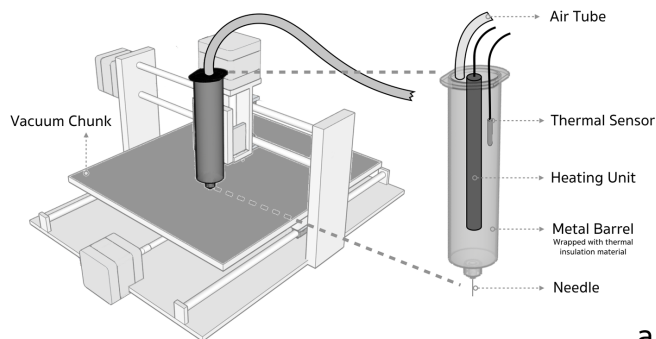

Figure 8. The NoHAS System: (a) Structure of the sealing module. (b) System framework

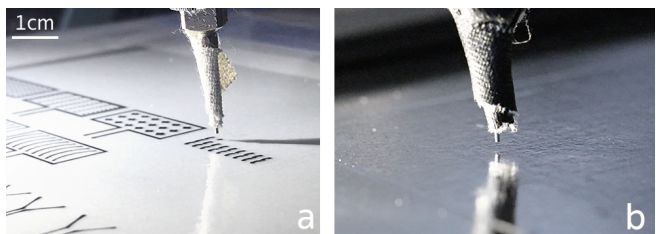

Figure 9. Sealing thin film with NoHAS: (a) Sealing Clear film. (b) Sealing metallized film

element should have a needle-like tip with a tiny cross-section area. As the tip becomes smaller, a higher pressure and greater heat exposure will cause scratching, penetrating, or even cutting of the thin film. To avoid this, we developed a hot air sealing tool with high precision. Hot air sealing is usually used as a large area sealing method [37]. By using millimeter scale needle tips ($\leq 24 \text{ g}$) to reduce the diameter of air flow, we are able to create precise sealing seams. The NoHAS system (Figure 8) consists of a sealing module that sits on top of a 3-axis CNC gantry. The sealing module contains a joule heating unit and a thermal sensor. They are integrated inside a stainless metal dispensing barrel which can bear high air pressure and temperature. An external thermal controller is used to regulate the temperature. The barrel is connected to a pneumatic dispenser (Nordson, Ultimius V) for precise pressure control. The dispenser is then connected to a compressed air pump. As the pressured air from the dispenser travels through the barrel, the heating unit quickly heats up the air to an ideal temperature (usually $180 \text{ }^\circ\text{C}$) for sealing. The heated air flows through the needle tip with an optimized pressure ($\geq 2 \text{ bar}$), which pushes the two layers of thin film against each other and seals. With this method, no contact will be made between the heat sealing element and the thin films

to avoid damage. It also preserves the coating on the thin film, which can be used for other purposes - in our case, sensing and heating. Figure 9 shows the metal coating on film is perfectly reserved with NoHAS.

Many factors will contribute to the quality of seams, such as the air temperature, CNC feed rate, the needle diameter and air pressure. We set the temperature at the recommended value of the film (e.g. 180°C for Mylar). The feed rate is set at 300 mm/min which provides a good balance between seam quality and sealing time. The seam width is mainly determined by the needle size and the Needle-Film Distance(NFD). For a 2 mm NFD and 24 g needle which has an inner diameter of 0.3 mm, the seam width can be as thin as 0.4 mm. As NFD increases, the heat and force applied on the substrate declines. The seam width will decline until, at a certain NFD, the film cannot be sealed, which is ~4mm at 2 bar, 180°C and 300 mm/min. When the needle size and NFD is fixed, the seal strength will be positively related to the air pressure.

A micro-porous vacuum chuck (ClampuSystems, VT3122MP) is used to fix the thin film on the platform. The bottom layer of film should be cut smaller than the top layer, so that the top layer can be clamped to the vacuum chuck. Once the film is fixed and the NoHAS platform is set, users can send G-Code to the machine and begin fabrication.

Circuit Fabrication

Adding sensing ability to milliMorph composite is crucial for creating interactivity. To avoid negative impact on the deformation performance of the soft milliMorph composite, we hope to create ultra thin sensing circuits directly on the fluid chamber. In the past few decades, technologies have been developed to fabricate soft and flexible circuits[11, 33, 34]. While many of those methods are not applicable to create circuits on thin film, other methods, such as screen printing[14, 36] have been developed to make circuits as thin as 20 μm. Films that are specially designed for making soft PCBs can be etched easily to making circuit, but the metal coating is quite thick, usually dozens of micrometers [5]. Off-the-shelf inkjet printers have been used to print circuits hundreds of nanometers thick. However, it requires quite expensive ink and special substrate with a coating for chemical or heat sintering[6, 7, 8], which would damage the thermal plastic that we use for heat sealing.

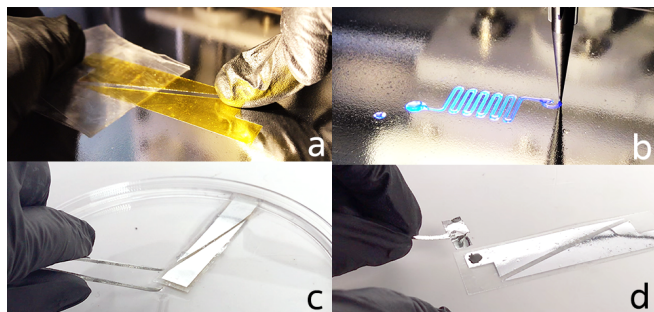

Figure 10. Circuit Fabrication: (a) Coating manually; (b)Coating robotically; (c)Etching in 2 mol/L NaOH Solution; (d)Cold soldering

We noticed the PET film coated with aluminum dozens of nanometers thick is widely available at quite a low cost (e.g. party balloons). The ultra thin coat is strongly bonded to the substrate and quite conductive for making sensing elements. Utilizing this coat, we developed a simple process to make functional circuits that are inherently integrated with the fluid chambers. The film is first masked via transferring pre-cut tapes manually or dispensing UV sensitive resin robotically by changing the sealing module with a dispensing syringe (Figure 10.a,b). The masked film is then placed in 2 mol/L NaOH solution for ~10 seconds (Figure 10.c). After the bared aluminum is etched off, the film is cleaned with water. The resin or tape can be then stripped off, leaving the circuit on top of the film. The process can be also adapted to etch other metal coatings such as copper or silver, with matching solution.

The etched film then can be cold soldered with external wires using conductive ink such as MG Chemicals Nickel Print (Figure 10.d). Before the circuit is connected to power, we also coated it with a protective layer. One reason is that the thermoplastic will shrink when the circuit overheats it. Even though the thermal contraction rate could be very low, it's still fatal to our ultra-thin metal coat, resulting in numerous micro cracks. A protective layer will help the circuit maintain integrity and conductivity. We also use PWM control to avoid overheating. For the sensing circuit, no cracks will happen and the protective layer is mainly for insulation. We use Mod Podge as the protective layer. The Mod Podge is sprayed on manually and sits for ~30 seconds before using.

Cutting, Connecting, Injecting and Closing Seal

As a drag knife cutting tool sometimes scratches the chuck, for now we cut the film manually. The milliMorph composites then can be connected with a needle or tube before closing the seal. Glue sticks can be used for quick connection, while silicon sealant can be adopted for higher air-/liquid- tightness. For composites that will be actuated via low boiling point, no external connection is required. Users can simply inject the liquid, then do the final sealing.

APPLICATION EXAMPLES

Actuated Mini Robot

The rapid oscillation and lightness properties of milliMorph naturally lead to the idea of imitating insect wings. Many insects' locomotion are fluid-based systems. Inspired by that, we designed a butterfly with flapping wings.

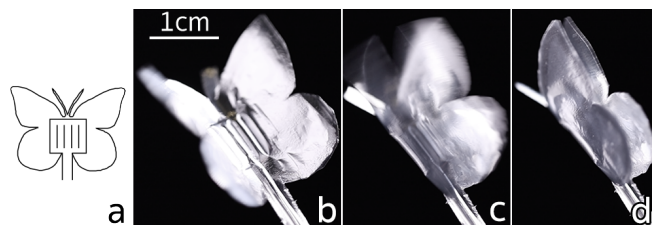

Figure 11. A mini butterfly robot: (a) Digital Design. (b-d) The butterfly beats its wings at 10 Hz

Figure 11.a shows the design. In the middle of the body are the fluid chambers that act as muscle. The wing parts also

have some seams sealed which act as veins to reinforce the thin film. When connected with a pipette, the butterfly can be a toy actuated by squeezing. When connected to computer controlled valves, the wings can oscillate at 10 Hz, which matches a living butterfly. However, due to the weight of the tubes, the butterfly is not able to elevate.

3D & 4D Fabrication

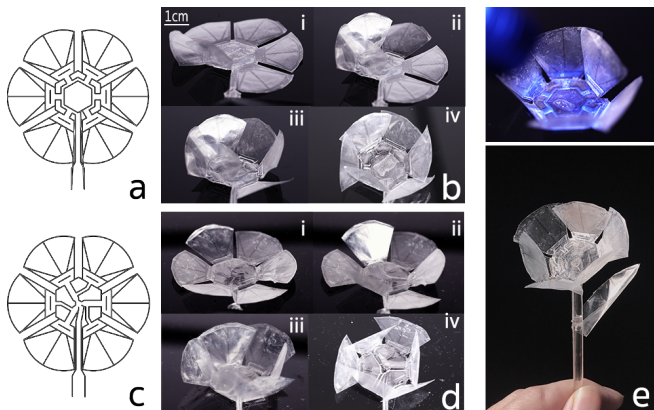

Figure 12. Sequentially controlled folding: (a,c) Digital Design. (b) Rosaceous folding. (d) Liliaceous folding. (e) Resin injected and cured.

By Carefully observing different kinds of flowers, you will notice that they are not only unique in shape and color. The topology of petals also contribute to their motion of blooming, which inspired us to make this flower-like prototype (Figure 12). The flowers have the same chambers on every petal, but the channels connecting the chambers are artfully designed in order to fill the chambers in a certain sequence. The two examples show petals folding one by one or group by group, ending in two different corolla morphology forms which are liliaceous and rosaceous [29] (Figure 12.b,d). Sequential shape change is an emerging research field [1, 26]. MilliMorph provides a reversible approach. Moreover, the sequential folding can also be fixed with photosensitive resin injected and UV light applied (Figure 12.d).

Haptic Latex Glove

Various forms of actuation methods, including the pneumatic method, have been developed to provide haptic feedback [4, 16, 18, 36]. Previous pneumatic tactile displays are usually thick and non-flexible. With milliMorph, we can make very thin tactile displays that are quite conformable to other types of surfaces. Latex gloves are widely used in chemistry/biology labs. Although gloves provide protection, it deprives fingers of tactile sensations. A thin milliMorph film adhered to the internal surface of latex gloves could provide haptic feedback with texture change. For example, if a low boiling point liquid is injected, milliMorph would change texture when the user touches something hot, thereby providing a haptic alert and better thermal insulation by turning into gas. The soft thin interface can deform well along the substrate when inactive (Figure 13). We carried out a pilot experiment regarding this. A pair of gloves were made, but only one of them had Novec™ 71DE (boiling point 41°C) injected. Five users were

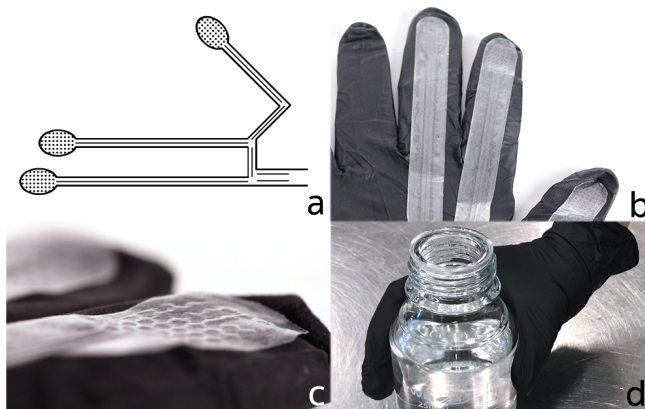

Figure 13. Haptic Latex Gloves: (a) Digital Design. (b) Stuck to the internal surface of a glove. (c) A close look at the texture change. (d) Respond to heat source when low-boiling point liquid injected.

asked to wear the gloves and touch a bottle filled with water heated at 80°C. Four of five said they could feel the textile change and correctly pointed out which one had 71DE inside. Two of them thought the change was subtle, while the other two argued that the change was obvious. Three of them also indicated that they felt the temperature on the fingertip area went up slower.

Responsive Bracelet

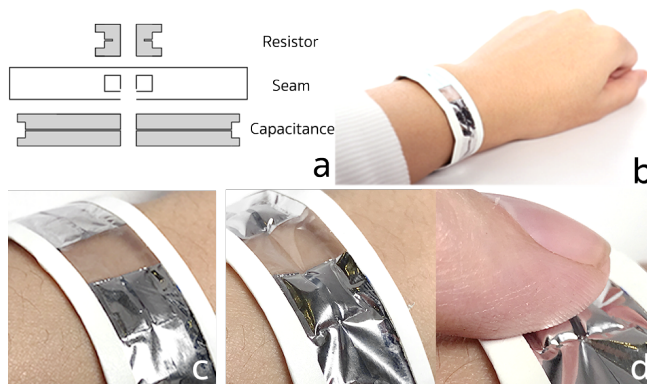

Figure 14. Responsive bracelet: (a) Digital design. (b) Overview. (c) Idle. (c,d) Activated and buttons appear

The responsive bracelet exemplifies the potential of milliMorph to be an integrated and portable interface. The bracelet is fabricated with metallized film. It has two buttons filled with low boiling point liquid which will only show up when needed. The bottom layer is etched with a heating circuit, and the top layer is etched with a touch sensor. The function of the buttons can be customized according to the scenario. For example, when a call comes in, the buttons will show up. The user then can answer or hang up the phone by pressing the buttons. The buttons will disappear once the call is over (Figure 14). Currently the prototype is connected to an external power source and control board. A small customized battery and control board can be integrated to make it wearable.

The button in this example is $\sim 6 \text{ mm} \times 6 \text{ mm}$ and will fully inflate in 3 s (3 V 0.3 A, NovacTM 71DE inside), reverse in 6 s. By fabricating smaller chambers and utilizing the bending mechanism to generate button shape, the energy consumption can be further reduced and response time can be shorter.

Shape-Changing Sticker

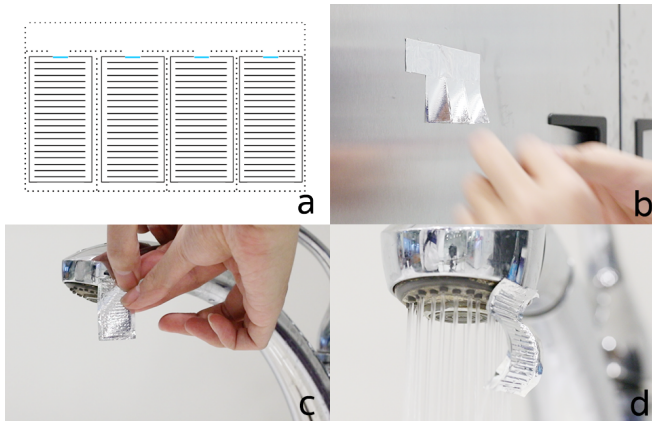

Figure 15. Shape-changing sticker: (a) Digital design. The black line represents seams, the dotted line represents where needs to be pre-cut, and the blue line represents where needs to be sealed after the liquid is injected. (b,c) A sticker is torn and stuck to a tap. (d) The sticker is actuated by hot water.

When filled with low-boiling temperature liquid, milliMorph can be untethered and highly responsive to environmental heat. These qualities make milliMorph ideal to be a self-contained responsive composite material. Shape-changing stickers are composed of multiple adhesive strips ($20 \text{ mm} \times 40 \text{ mm}$) sealed with $\sim 1.5 \text{ mm}$ wide chambers. NovacTM 7000 (boiling point 34°C) is injected. The strip is already pre-cut and can be easily torn apart. The sticker can then be pasted to the area where the environmental temperature is changing. For example, the sticker can be pasted to a tap to indicate whether the water is hot, helping people avoid scalding (Figure 15). The sticker fully bends in less than 1 s under 50°C water flow and reverses in $\sim 2.5 \text{ s}$ at room temperature 20°C . We tested a sticker seal with two big chambers ($20 \text{ mm} \times 20 \text{ mm}$). It takes $\sim 2 \text{ s}$ to bend and 5-7 s to reverse. Liquid with different boiling points can be used according to the desired threshold temperature. In this example scenario, metallized film is used to make the sticker fit in a kitchen elegantly.

LIMITATION AND FUTURE WORK

While milliMorph has exciting potential as a shape-change material, there are also limitations and space for improvement. Below we discuss its current limitations and future works.

Multiple Layers

Currently, the milliMorph films only have one layer of chambers. By sealing more than two layers of film together, multiple layers of chambers and channels can be made. Another layer of chambers that actuate the composites to change shape inversely can greatly reduce reverse time, increasing oscillation frequency. Extra chambers and channel layers can be used to

form some logical control "circuit" [20]. Different layers of chambers can be injected with different mediums, combining multiple functions.

Ultra-thin Film

While researchers have been pushing electronic film down to a few micrometers [6], current research on shape-changing materials for interaction design remains relatively thick. Ultra-thin heat sealable film ($\sim 6 \mu\text{m}$) is quite expensive, yet worth trying. In the future, we would like to try to push the thickness limitation of shape-changing interfaces by fabricating with ultra-thin composites using NoHAS.

Improving Sensing Technique

Embedded circuits etched on metallized film perfectly conforms with milliMorph composites as a single entity. This is a great advantage compared to the option of adding another circuit layer. However, the circuits transform easily when the composites fold or drape, which would cause capacitance change. We can utilize this to detect the status of the composites, however it could be noise for touching or sliding sensing simultaneously. Further analysis and algorithm improvements need to be made.

Expanding Actuation Medium Library

Excluding the actuation mediums mentioned above, there are many other materials that can enrich the design space. For example, with the phase change of liquid metal, the stiffness of milliMorph can be changed reversibly. Thermochromic dyes could be dissolved in water and injected, to allow the ability of responding to temperature change with both shape and color to milliMorph. Expanding the library of actuation mediums would be a very exciting direction to explore.

CONCLUSION

In this paper, we demonstrated a design space of fluid-based shape-change materials at millimeter scale for HCI. The ability to design and fabricate millifluidic chambers allows one to create high frequency actuation, sequential control of flows and high resolution design with thin film materials. We described a novel platform that enables precise millifluidics fabrication, and application demonstrations of how milliMorph films can be used in interaction and product design. We believe that as fabrication resolutions increase, designers will be able to create materials with extraordinary properties or transformations beyond visual means. Our work demonstrated that by scaling down the fabrication scale, we can continue expanding the design space of fluid-based shape-change materials.

ACKNOWLEDGMENTS

We would like to thank everybody who helped in conducting this research and creating this paper. Especially, but not limited to: Joanne Leong, Ken Nakagaki, Deema Qashat, Paula Aguilera, Jonathan Williams, Yuting Diao, and Yingqing Xu.

REFERENCES

- [1] Byoungkwon An, Ye Tao, Jianzhe Gu, Tingyu Cheng, Xiang 'Anthony' Chen, Xiaoxiao Zhang, Wei Zhao, Youngwook Do, Shigeo Takahashi, Hsiang-Yun Wu,

- Teng Zhang, and Lining Yao. 2018. Thermorph: Democratizing 4D Printing of Self-Folding Materials and Interfaces. In *Proceedings of the 2018 CHI Conference on Human Factors in Computing Systems (CHI '18)*. ACM, Article 260, 12 pages.
- [2] Alexandra Delazio, Ken Nakagaki, Roberta L. Klatzky, Scott E. Hudson, Jill Fain Lehman, and Alanson P. Sample. 2018. Force Jacket: Pneumatically-Actuated Jacket for Embodied Haptic Experiences. In *Proceedings of the 2018 CHI Conference on Human Factors in Computing Systems (CHI '18)*. ACM, Article 320, 12 pages.
- [3] Sean Follmer, Daniel Leithinger, Alex Olwal, Nadia Cheng, and Hiroshi Ishii. 2012. Jamming User Interfaces: Programmable Particle Stiffness and Sensing for Malleable and Shape-changing Devices. In *Proceedings of the 25th Annual ACM Symposium on User Interface Software and Technology (UIST '12)*. ACM, 519–528.
- [4] Liang He, Cheng Xu, Ding Xu, and Ryan Brill. 2015. PneuHaptic: Delivering Haptic Cues with a Pneumatic Armband. In *Proceedings of the 2015 ACM International Symposium on Wearable Computers (ISWC '15)*. ACM, 47–48.
- [5] Felix Heibeck, Basheer Tome, Clark Della Silva, and Hiroshi Ishii. 2015. uniMorph: Fabricating Thin Film Composites for Shape-Changing Interfaces. In *Proceedings of the 28th Annual ACM Symposium on User Interface Software and Technology (UIST '15)*. ACM, 233–242.
- [6] Martin Kaltenbrunner, Tsuyoshi Sekitani, Jonathan T Reeder, Kazunori Kuribara, Takeyoshi Tokuhara, M. Drack, Reinhard Schwödiauer, Ingrid M. Graz, Simona Bauer-Gogonea, Siegfried Bauer, and Takao Someya. 2013. An ultra-lightweight design for imperceptible plastic electronics. *Nature* 499 (2013), 458–463.
- [7] Byung Ju Kang, Chang Kyu Lee, and Je Hoon Oh. 2012. All-inkjet-printed electrical components and circuit fabrication on a plastic substrate. *Microelectronic Engineering* 97 (2012), 251–254.
- [8] Yoshihiro Kawahara, Steve Hodges, Benjamin S. Cook, Cheng Zhang, and Gregory D. Abowd. 2013. Instant Inkjet Circuits: Lab-based Inkjet Printing to Support Rapid Prototyping of UbiComp Devices. In *Proceedings of the 2013 ACM International Joint Conference on Pervasive and Ubiquitous Computing (UbiComp '13)*. ACM, 363–372.
- [9] Nicholas Kellaris, Vidyacharan Gopaluni Venkata, Garrett M Smith, Shane K Mitchell, and Christoph Keplinger. 2018. Peano-HASEL actuators: Muscle-mimetic, electrohydraulic transducers that linearly contract on activation. *Science Robotics* 3, 14 (2018), eaar3276.
- [10] Shuguang Li, Daniel M. Vogt, Daniela Rus, and Robert J. Wood. 2017. Fluid-driven origami-inspired artificial muscles. *Proceedings of the National Academy of Sciences* 114, 50 (2017), 13132–13137.
- [11] Steven Nagels, Raf Ramakers, Kris Luyten, and Wim Deferme. 2018. Silicone Devices: A Scalable DIY Approach for Fabricating Self-Contained Multi-Layered Soft Circuits Using Microfluidics. In *Proceedings of the 2018 CHI Conference on Human Factors in Computing Systems (CHI '18)*. ACM, Article 188, 13 pages.
- [12] Kenichi Nakahara, Koya Narumi, Ryuma Niiyama, and Yoshihiro Kawahara. 2017. Electric phase-change actuator with inkjet printed flexible circuit for printable and integrated robot prototyping. In *2017 IEEE International Conference on Robotics and Automation (ICRA)*. 1856–1863.
- [13] Ryuma Niiyama, Xu Sun, Lining Yao, Hiroshi Ishii, Daniela Rus, and Sangbae Kim. 2015. Sticky Actuator: Free-Form Planar Actuators for Animated Objects. In *Proceedings of the Ninth International Conference on Tangible, Embedded, and Embodied Interaction (TEI '15)*. ACM, 77–84.
- [14] Simon Olberding, Michael Wessely, and Jürgen Steimle. 2014. PrintScreen: Fabricating Highly Customizable Thin-film Touch-displays. In *Proceedings of the 27th Annual ACM Symposium on User Interface Software and Technology (UIST '14)*. ACM, 281–290.
- [15] Jifei Ou, Gershon Dublon, Chin-Yi Cheng, Felix Heibeck, Karl Willis, and Hiroshi Ishii. 2016a. Cillia: 3D Printed Micro-Pillar Structures for Surface Texture, Actuation and Sensing. In *Proceedings of the 2016 CHI Conference on Human Factors in Computing Systems (CHI '16)*. ACM, 5753–5764.
- [16] Jifei Ou, Mélina Skouras, Nikolaos Vlavianos, Felix Heibeck, Chin-Yi Cheng, Jannik Peters, and Hiroshi Ishii. 2016b. aeroMorph - Heat-sealing Inflatable Shape-change Materials for Interaction Design. In *Proceedings of the 29th Annual Symposium on User Interface Software and Technology (UIST '16)*. ACM, 121–132.
- [17] Jifei Ou, Lining Yao, Daniel Tauber, Jürgen Steimle, Ryuma Niiyama, and Hiroshi Ishii. 2013. jamSheets: Thin Interfaces with Tunable Stiffness Enabled by Layer Jamming. In *Proceedings of the 8th International Conference on Tangible, Embedded and Embodied Interaction (TEI '14)*. ACM, 65–72.
- [18] Roshan Lalintha Peiris, Wei Peng, Zikun Chen, Liwei Chan, and Kouta Minamizawa. 2017. ThermoVR: Exploring Integrated Thermal Haptic Feedback with Head Mounted Displays. In *Proceedings of the 2017 CHI Conference on Human Factors in Computing Systems (CHI '17)*. ACM, 5452–5456.
- [19] Tommaso Ranzani, Sheila Russo, Nicholas W. Bartlett, Michael Wehner, and Robert J. Wood. 2018. Increasing the Dimensionality of Soft Microstructures through Injection-Induced Self-Folding. *Advanced Materials* 30, 38 (2018), 1802739.

- [20] Minsoung Rhee and Mark A Burns. 2009. Microfluidic pneumatic logic circuits and digital pneumatic microprocessors for integrated microfluidic systems. *Lab on a chip* 9, 21 (2009), 3131–3143.
- [21] Sheila Russo, Tommaso Ranzani, Conor J. Walsh, and Robert J. Wood. 2017. An Additive Millimeter-Scale Fabrication Method for Soft Biocompatible Actuators and Sensors. *Advanced Materials Technologies* 2, 10 (2017), 1700135.
- [22] Harpreet Sareen, Udayan Umapathi, Patrick Shin, Yasuaki Kakehi, Jifei Ou, Hiroshi Ishii, and Pattie Maes. 2017. Printflatables: Printing Human-Scale, Functional and Dynamic Inflatable Objects. In *Proceedings of the 2017 CHI Conference on Human Factors in Computing Systems (CHI '17)*. ACM, 3669–3680.
- [23] Christian Schumacher, Bernd Bickel, Jan Rys, Steve Marschner, Chiara Daraio, and Markus Gross. 2015. Microstructures to Control Elasticity in 3D Printing. *ACM Trans. Graph.* 34, 4, Article 136 (July 2015), 13 pages.
- [24] Robert F. Shepherd, Filip Ilievski, Wonjae Choi, Stephen A. Morin, Adam A. Stokes, Aaron D. Mazzeo, Xin Chen, Michael Wang, and George M. Whitesides. 2011. Multigait soft robot. *Proceedings of the National Academy of Sciences* 108, 51 (2011), 20400–20403.
- [25] Liang Shi, Vahid Babaei, Changil Kim, Michael Foshey, Yuanming Hu, Pitchaya Sitthi-Amorn, Szymon Rusinkiewicz, and Wojciech Matusik. 2018. Deep Multispectral Painting Reproduction via Multi-layer, Custom-ink Printing. *ACM Trans. Graph.* 37, 6, Article 271 (Dec. 2018), 15 pages.
- [26] Skylar Tibbits, Carrie McKnelly, Carlos Olguin, Daniel Dikovsky, and Shai Hirsch. 2014. 4D Printing and universal transformation. (2014).
- [27] Cesar Torres, Tim Campbell, Neil Kumar, and Eric Paulos. 2015. HapticPrint: Designing Feel Aesthetics for Digital Fabrication. In *Proceedings of the 28th Annual ACM Symposium on User Interface Software and Technology (UIST '15)*. ACM, 583–591.
- [28] Ryan L. Truby, Michael Wehner, Abigail K. Grosskopf, Daniel M. Vogt, Sebastien G. M. Uzel, Robert J. Wood, and Jennifer A. Lewis. 2018. Soft Somatosensitive Actuators via Embedded 3D Printing. *Advanced Materials* (2018).
- [29] Shiro Tsuyuzaki. 2018. Plant morphology: Terms for morphology. (2018). <http://hosho.ees.hokudai.ac.jp/~tsuyu/top/dct/morph.html>.
- [30] Takahiro Uji, Yiting Zhang, and Hiromasa Oku. 2017. Edible Retroreflector. In *Proceedings of the 23rd ACM Symposium on Virtual Reality Software and Technology (VRST '17)*. ACM, Article 5, 8 pages.
- [31] Marynel Vázquez, Eric Brockmeyer, Ruta Desai, Chris Harrison, and Scott E. Hudson. 2015. 3D Printing Pneumatic Device Controls with Variable Activation Force Capabilities. In *Proceedings of the 33rd Annual ACM Conference on Human Factors in Computing Systems (CHI '15)*. ACM, 1295–1304.
- [32] M. Wehner, R. L. Truby, D. J. Fitzgerald, B. Mosadegh, G. M. Whitesides, J. A. Lewis, and R. J. Wood. 2016. An integrated design and fabrication strategy for entirely soft, autonomous robots. *Nature* 536 (2016), 451–466.
- [33] Martin Weigel, Tong Lu, Gilles Bailly, Antti Oulasvirta, Carmel Majidi, and Jürgen Steimle. 2015. iSkin: Flexible, Stretchable and Visually Customizable On-Body Touch Sensors for Mobile Computing. In *Proceedings of the 33rd Annual ACM Conference on Human Factors in Computing Systems (CHI '15)*. ACM, 2991–3000.
- [34] Michael Wessely, Theophanis Tsandilas, and Wendy E. Mackay. 2016. Stretchis: Fabricating Highly Stretchable User Interfaces. In *Proceedings of the 29th Annual Symposium on User Interface Software and Technology (UIST '16)*. ACM, 697–704.
- [35] Karl Willis, Eric Brockmeyer, Scott Hudson, and Ivan Poupyrev. 2012. Printed Optics: 3D Printing of Embedded Optical Elements for Interactive Devices. In *Proceedings of the 25th Annual ACM Symposium on User Interface Software and Technology (UIST '12)*. ACM, 589–598.
- [36] Anusha Withana, Daniel Groeger, and Jürgen Steimle. 2018. Tacttoo: A Thin and Feel-Through Tattoo for On-Skin Tactile Output. In *Proceedings of the 31st Annual ACM Symposium on User Interface Software and Technology (UIST '18)*. ACM, 365–378.
- [37] Junichi Yamaoka, Ryuma Niiyama, and Yasuaki Kakehi. 2017. BlowFab: Rapid Prototyping for Rigid and Reusable Objects Using Inflation of Laser-cut Surfaces. In *Proceedings of the 30th Annual ACM Symposium on User Interface Software and Technology (UIST '17)*. ACM, 461–469.
- [38] Lining Yao, Ryuma Niiyama, Jifei Ou, Sean Follmer, Clark Della Silva, and Hiroshi Ishii. 2013. PneuUI: Pneumatically Actuated Soft Composite Materials for Shape Changing Interfaces. In *Proceedings of the 26th Annual ACM Symposium on User Interface Software and Technology (UIST '13)*. ACM, 13–22.
- [39] Lining Yao, Jifei Ou, Chin-Yi Cheng, Helene Steiner, Wen Wang, Guanyun Wang, and Hiroshi Ishii. 2015. bioLogic: Natto Cells As Nanoactuators for Shape Changing Interfaces. In *Proceedings of the 33rd Annual ACM Conference on Human Factors in Computing Systems (CHI '15)*. ACM, 1–10.
- [40] Jonas Zehnder, Espen Knoop, Moritz Bäcker, and Bernhard Thomaszewski. 2017. Metasilicone: Design and Fabrication of Composite Silicone with Desired Mechanical Properties. *ACM Trans. Graph.* 36, 6, Article 240 (Nov. 2017), 13 pages.